

## Preliminary finite element analysis of the stainless-steel liner of the maintainable test cell concept of IFMIF-DONES

I. Katona<sup>a,\*</sup>, M. Tóth<sup>a</sup>, J. Castellanos<sup>b,h</sup>, F. Arbeiter<sup>c</sup>, T. Dézsi<sup>d</sup>, A. Zsákai<sup>a</sup>, G. Micciche<sup>e</sup>, Y. Qiu<sup>c</sup>, M. Siwek<sup>f</sup>, D. Alonso<sup>g</sup>, C. Melendez<sup>g</sup>, F. Rueda<sup>g</sup>, A. Ibarra<sup>b</sup>

<sup>a</sup> Centre for Energy Research, Budapest, Hungary

<sup>b</sup> National Fusion Laboratory, CIEMAT, Madrid, Spain

<sup>c</sup> Karlsruhe Institute of Technology (KIT), Karlsruhe, Germany

<sup>d</sup> Centre for Energy Research/ C3D Engineering Ltd, Budapest, Hungary

<sup>e</sup> Fusione e Tecnologia per la Sicurezza Nucleare, ENEA, Camugnano, Italy

<sup>f</sup> Institute of Plasma Physics and Laser Microfusion (IPPLM), Warsaw, Poland

<sup>g</sup> Esteyco S. A., Menéndez Pidal, 17, 28036 Madrid, Spain

<sup>h</sup> INAIA, University of Castilla-La Mancha, Toledo, Spain

### ARTICLE INFO

#### Keywords:

IFMIF-DONES  
Test cell  
Biological shielding  
Removable liner  
Maintenance  
FEM analysis

### ABSTRACT

The main purpose of IFMIF-DONES facility is to provide a neutron source for irradiating small specimens and producing experimental data of material properties for the construction of DEMO fusion power plant. The Test Cell (TC) of the DONES is a confined and well-shielded room, where the strong irradiation environment is created. The biological shielding of the TC mainly consists of several meters thick concrete walls and shielding plugs, and a stainless-steel liner. The TC liner and the concrete walls are actively cooled by water because of the high volumetric heating coming from nuclear reactions. Although, the TC is designed to be fully functional for the complete life span of the facility, still there is a very low probability of defect of the TC biological shielding due to their exposure of intense neutron and gamma irradiation. Therefore, the original TC configuration, which was a monolithic approach, had to be revised. Due to this reason, at the end of 2019 the project team has changed the TC concept from the monolithic design to the so-called Maintainable TC Concept (MTCC) design, which allows a maintenance possibility in case of unexpected damage.

### 1. Introduction

The aim of this paper is to describe the MTCC and its conceptual design and to describe the preliminary Finite Element Method (FEM) analysis of the stainless-steel liner, which serves as the vacuum boundary. In this study a simplified shell model was made from the 3D CAD geometry of the liner. The loads of the components were represented as point masses, the thermal load caused by the irradiation was available from another study. An optimization was conducted in regards of the deformation of the geometry and the stress field and changes to the TC liner were introduced accordingly.

The IFMIF-DONES (International Fusion Materials Irradiation Facility DEMO Oriented Neutron Source) [1] project's purpose is to understand the degradation of the materials and components' properties throughout the DEMO experimental fusion reactor operational life. The

highest impact will be on the first wall of the reactor [2], therefore material testing will focus on candidates for the first wall.

IFMIF-DONES comprises of five main systems: Accelerator Systems, Lithium Systems, Site, Buildings & Plant Systems, Central Instrumentation & Control Systems and finally, Test Systems. [3].

The Test Cell (TC) is part of the Test Systems, and its main purposes is to contain and confine the irradiation modules with their material specimens and to shield, by means of thick concrete blocks, the high-energy neutrons produced inside the TC by the deuteron-lithium interaction; in this sense, the TC system can be considered the heart of IFMIF-DONES facility. The previous design base [4] was a monolithic approach, where all concrete and Test Cell liner was considered as permanently fixed, but it turned out during later studies that this approach is not going to be feasible due to possible accidental events and their nearly impossible mitigation procedures (e.g., concrete cooling

\* Corresponding author.

E-mail address: [katona.imre@ek-cer.hu](mailto:katona.imre@ek-cer.hu) (I. Katona).

<https://doi.org/10.1016/j.nme.2022.101186>

Received 29 October 2021; Received in revised form 14 April 2022; Accepted 18 April 2022

Available online 20 April 2022

2352-1791/© 2022 The Authors. Published by Elsevier Ltd. This is an open access article under the CC BY license (<http://creativecommons.org/licenses/by/4.0/>).

pipe rupture). A preliminary analysis was conducted to see the possibility of changing the approach to a maintainable one, thus came the idea of the Maintainable Test Cell Concept (MTCC) [5].

## 2. Test cell liner (TC Liner)

The main changes from the monolithic concept are the separation of inner concrete to removable biological shielding blocks (RBSBs) and changing the Test Cell Liner (TC Liner) to a maintainable concept separating it from the concrete.

The Test Cell Liner is the safety and vacuum boundary of the Test Cell, thus strict requirements apply to its design. Such as:

- Variable environments from 1 hPa to 1 bar with He and Ar atmosphere
- Prevent Li contact with environment in case of a leakage
- withstand radiation, tritium production, and the intense Deuterium beam
- deformations should be low enough at critical points for positioning (support and positioning of HFTM and Target Assembly)

The Test Cell Liner itself is a large, welded structure. The chosen material for the liner is low cobalt SS316L to mitigate activation of the component. The TC Liner can be divided into 3 larger segments, as indicated on Fig. 1.

## 3. Tradespace analysis and simulation

A Multi Attribute Utility (MAU) tradespace study [6] has been carried out with various U profile (UPA, UPE, UPN, PFC) stiffeners as candidates. This is done to determine which stiffening outline would yield the best results in terms of stiffness (stiffness per mass) and cost (mass per surface and weld cross section) on the intermediate segment of the TC liner. The performance criteria (horizontal axis of Fig. 1) were calculated in terms of deflection using a simplified analytical formula:

$$d_{max} = \frac{1}{384} \frac{q_L L^4}{EI} \quad (1)$$

where maximum deflection  $d_{max}$  of a truss of length  $L$  homogeneously loaded by a Force per length  $q_L$ , both ends fixed against translation and rotation is calculated.

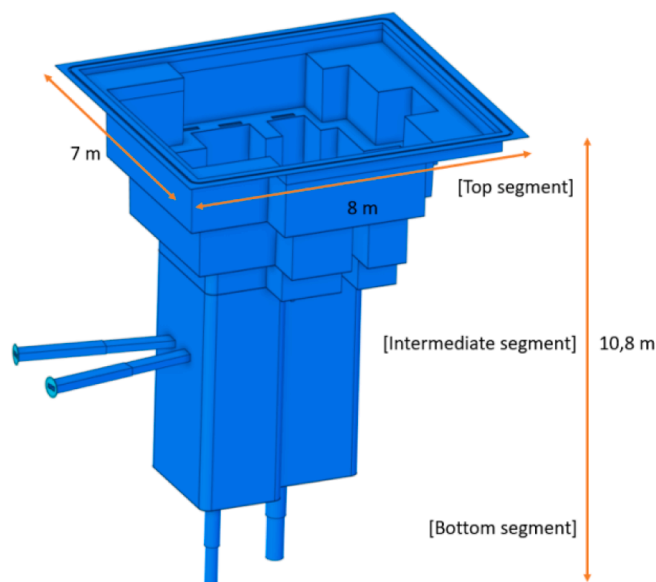

Fig. 1. Test Cell Liner main dimensions.

The TC liner was set to 15- and 20-mm thickness. The height of the profile was limited to 80 mm maximum due to Remote Handling constraints, while the spacing of the stiffener profile was varied.

More than a hundred versions have been analyzed and even if the analysis is an oversimplification of the design, the candidates for best results can be chosen and investigated further. A Pareto front has formed of potential candidates (Fig. 2, highlighted in green), where #31, #46 and #91 are PFC 260x75 profiles with different spacings and liner thickness, while #53, #56 and #59 are UPA 160, UPA 140 and UPA 120 profiles respectively with 1 stiffener per meter.

The dominant versions which are close in performance to the pareto front consisted of mainly PFC and UPA profiles with denser spacing and one UPN 220 profile. The UPE profiles did not perform well in the study.

## 4. Finite element analysis

Two candidates, #46 and #53, have been picked for FEM analysis based on the tradespace study. Candidate #46 has a TC Liner thickness of 15 mm and reinforced by PFC 260x75x28 profiles with 1 m spacing. Candidate #53 has a liner thickness of 15 mm and reinforced by UPA 160x80x8 profiles with 1 m spacing. #53 has a better welding surface (8 mm weld leg) than #46 (12 mm weld leg) but performs worse in terms of deflection according to analytical calculation.

The TC liner CAD model was simplified to a shell model to lower the required computing capacity. The analysis was carried out using ANSYS structural and Spaceclaim. A global 50 mm element size was applied to the model, while 10 mm mesh refinement was applied to the stiffener structure to obtain better results. Due to the shell model a good quality mesh was achieved. The minimal Element Quality was 0,2337 and the average was 0,9972. The mesh consisted of 1 979 812 nodes and 648 346 elements.

Due to the preliminary nature of the study fixed supports were used to simulate the connections to other components in the Test Cell. Including the Target Assembly (TA), inlet and outlet plug assembly (IPA and OPA), the through wall beam ducts (TWBD) and the connections to the concrete at the top of the liner (Fig. 3).

Two Removable Biological Shielding Block (RBSB) connection versions were analyzed:

- Variant 1: No fixation to RBSBs
- Variant 2: Fixation to top surfaces of RBSBs (horizontal surfaces) at the height of Lower shielding Plug (LSP), Upper Shielding Plug (USP) and Piping and Cabling Plugs (PCPs) [5]

The loads were also simplified in a conservative way. 1 bar differential pressure (vacuum inside) was applied to the liner walls, thermal loads were mapped from a previous study [7] on intermediate and bottom segments, while a unified 30 °C temperature field was applied to the top segment. The weights of components inside the Test Cell were represented as point masses applied to surfaces (Fig. 3), and the self-weight was also included (see Figs. 4 and 5).

## 5. Results

The selected two versions show promising results according to the full models, although further studies are needed. #46 shows slightly lower deformation and much better overall stress field in the intermediate segment than #53, however assessment of the 12 mm weld leg of #46 is needed. #53 in turn has an 8 mm weld leg thickness which is covered by the standard [8].

The maximum deformation of the intermediate segment in case of #46 and #53 is 20 mm in both cases, while the analytical deflection calculated in the tradespace study is 1.7 and 4 mm, respectively. The difference is caused by the analytical assumptions and the additional loads in the full FEM analysis. In a similar study made by KIT [9] they have found larger differences between analytical model and FEM section

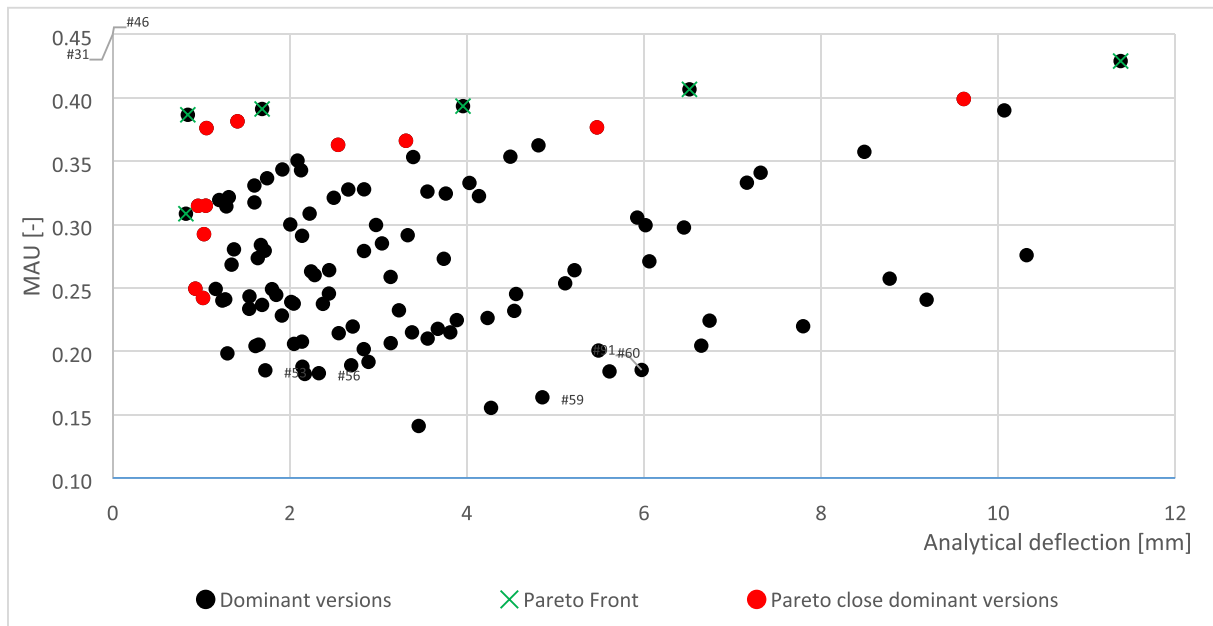

Fig. 2. Tradespace analysis of candidate stiffener profiles.

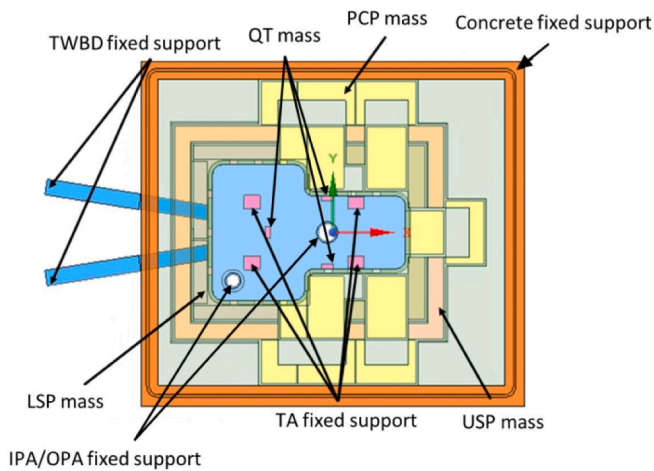

Fig. 3. Fixations and applied masses.

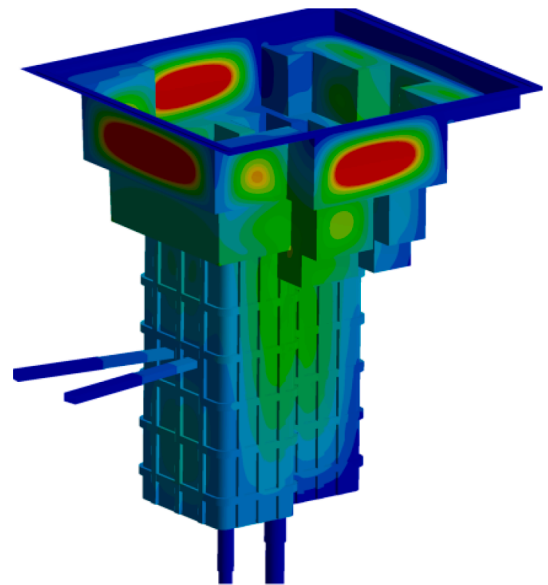

Fig. 5. #53 Candidate, Variant 1 – total deformation (same coloring as before).

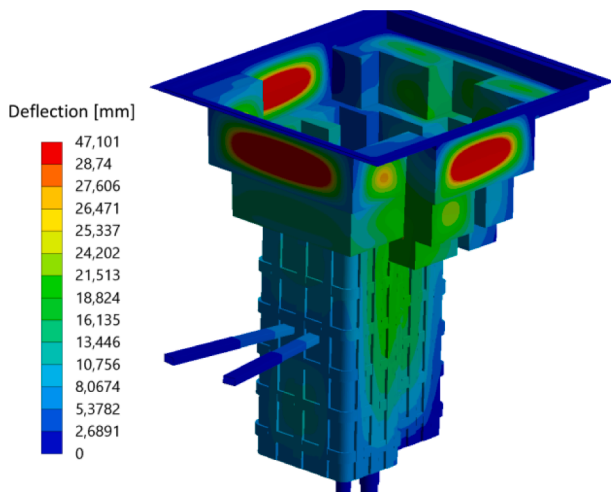

Fig. 4. #46 Candidate, Variant 1 – total deformation.

model. The real performance indicator is the stress field, where #46 shows better results than #53. The coloring of the stress fields is the same in each figure.

High stress areas are smaller and fewer in the intermediate part in case of #46 compared to #53 (Figs. 6 and 7), which indicates a better design. The extremely high stresses are caused by singularities in the model and can be ruled out from the simulation (see Figs. 8–11).

The top segment of the liner shows acceptable deformations and stress field when 30 mm liner is used instead of 15 mm.

Variant 2 of #46 and #53 performs better in terms of deflection due to the added fixation on top segment horizontal surfaces, however it does not help significantly on the stress field, the same concentrations can be seen on intermediate segment as in case of Variant 1, while the top segment is better reinforced using a thicker liner as previously shown.

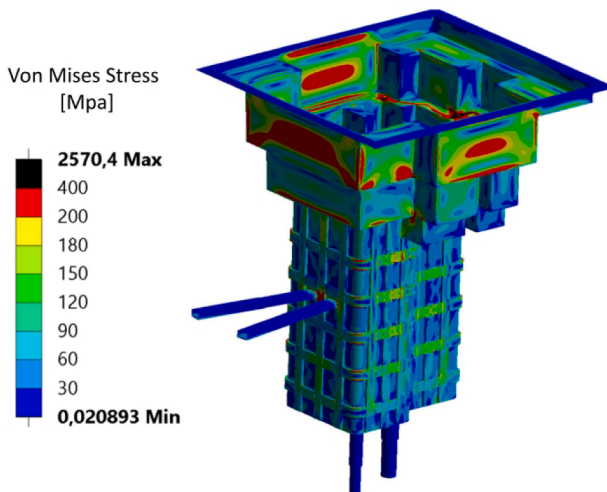

Fig. 6. #46 Candidate, Variant 1 – Equivalent Stress Field.

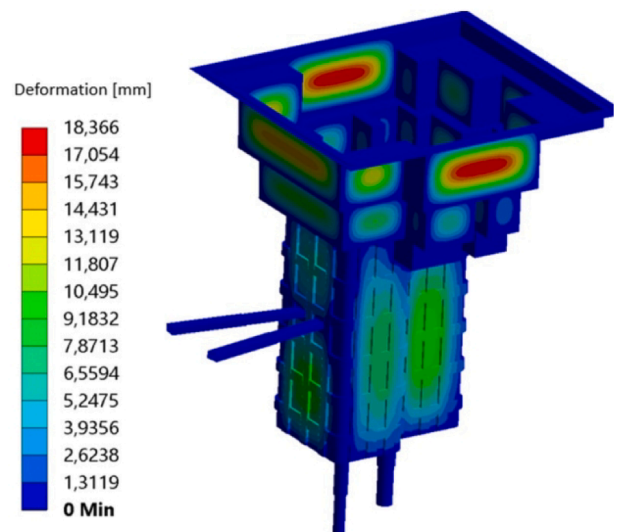

Fig. 9. #46 Candidate, Variant 2 – total.

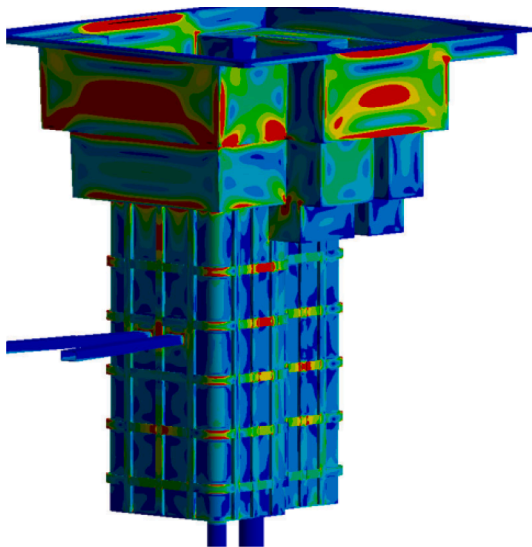

Fig. 7. #53 Candidate, Variant 1 – Equivalent Stress Field.

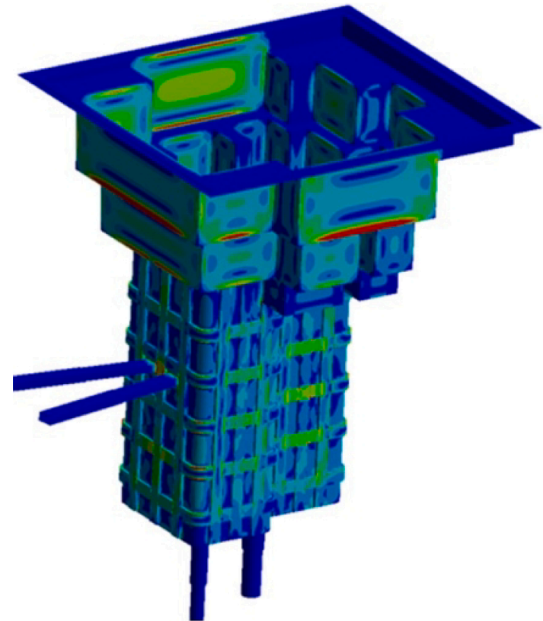

Fig. 10. #46 Candidate, Variant 2 – Stress Field.

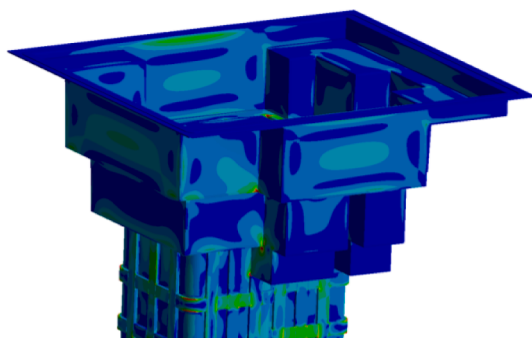

Fig. 8. #46 Candidate, Variant 1–30 mm thick top segment deformation.

## 6. Summary and conclusions

The MTCC's purpose is to have a maintainable design, where the TC liner is also a maintainable component and serves as a vacuum and safety boundary. There are several design problems due to the size of the component, which needs to be addressed either by simulation or

calculation. Therefore, a preliminary analysis has been conducted to see if the design is feasible and to identify the critical parts of the component.

During the preliminary analysis a tradespace study has been conducted to find candidates for the reinforcement of intermediate segment. Two candidates (#46 and #53) have been analysed. #46 showed better performance in terms of stress field than #53, however the weld leg of 12 mm needs to be qualified for #46. The top segment is better supported by thicker liner (30 mm) than using fixation to RBSBs. Further in-depth analysis is needed to study local stress peaks and introduce changes to reinforce locally the design.

## CRediT authorship contribution statement

**I. Katona:** Writing – original draft, Writing – review & editing, Methodology. **M. Tóth:** Conceptualization, Investigation. **J. Castellanos:** Supervision. **F. Arbeiter:** Resources, Supervision. **T. Dézsi:**

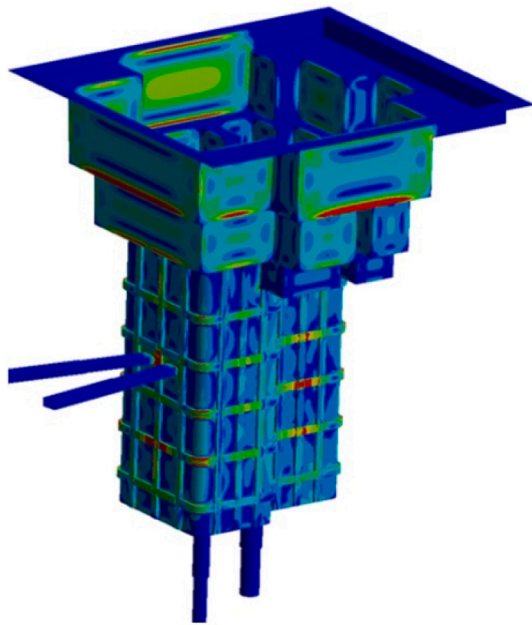

Fig. 11. #53 Candidate, Variant 2 – Stress Field.

Conceptualization, Validation. **A. Zsákai**: Visualization, Writing – review & editing. **G. Micciche**: Supervision. **Y. Qiu**: Formal analysis. **M. Siwek**: Data curation. **D. Alonso**: Data curation. **C. Melendez**: Supervision. **F. Rueda**: Data curation. **A. Ibarra**: Supervision, Project administration.

## Declaration of Competing Interest

The authors declare that they have no known competing financial interests or personal relationships that could have appeared to influence the work reported in this paper.

## Acknowledgments

This work has been carried out within the framework of the EUROfusion Consortium and has received funding from the Euratom research and training programme 2014-2018 and 2019-2020 under grant agreement No 633053. The views and opinions expressed herein do not necessarily reflect those of the European Commission.

## References

- [1] A. Ibarra et al.: The IFMIF-DONES project: Preliminary Engineering Design, 2018 Nucl. Fusion 58 105002.
- [2] Wurden, Glen, Scott, Willms: Engineering the fusion reactor first wall. United States: N. p., 2008. Web.
- [3] A. Ibarra et al.: The European approach to the fusion-like neutron source: the IFMIF-DONES project. Nucl. Fusion 59 065002 2019.
- [4] K. Tian, F. Arbeiter, S. Gordeev, F. Gröschel, Y. Qiu, The test cell configuration under IFMIF-DONES condition, Fus. Eng. Des. 124 (2017) 1112–1117.
- [5] K. Tian, F. Arbeiter, M. Ascott, O. Crofts, G. McIntyre, G. Micciche, G. Mitchell, Y. Qiu, M. Tóth, A. Ibarra, Preliminary analysis on a maintainable test cell concept for IFMIF-DONES, Fusion Eng. Design 146 (2019) 505–509.
- [6] <http://seari.mit.edu/mate.php>, (accessed 12 October 2021).
- [7] T. Dézsi et al., Thermal-hydraulic simulation of IFMIF-DONES Test Cell atmosphere, Fus. Eng. Des., Volume 167, 112336, 2021.
- [8] ISO 9692-1-2013 – Welding and Allied processes standard.
- [9] F. Arbeiter: Support to Test Cell Design, EFDA\_D\_2P66BF, 2020, Not published.